

SEARS

owners manual

MODEL NO.
161.21045

Caution:
Read Rules For
Safe Operation
and Complete
Operating Test
Procedures
Carefully

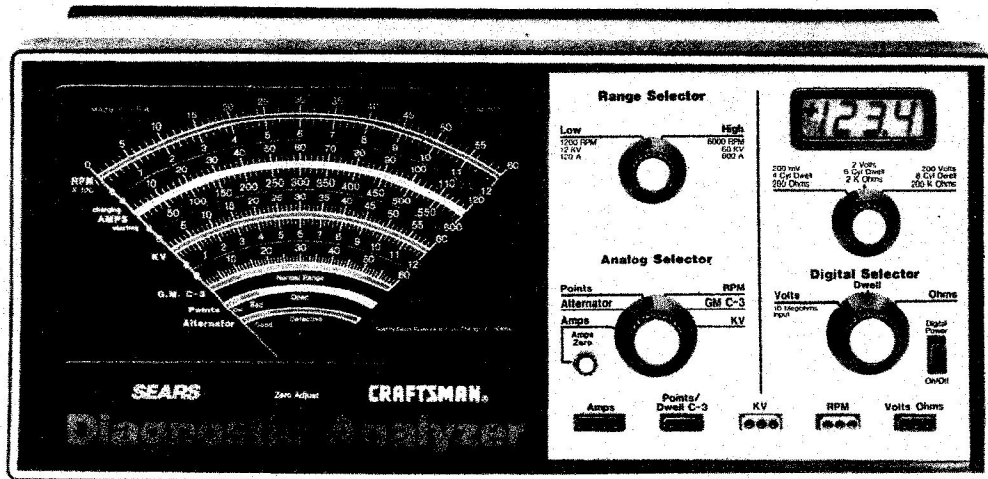

CRAFTSMAN®

DIAGNOSTIC ANALYZER

FOR 12 OR 24 VOLT SYSTEMS

- OPERATING INSTRUCTIONS
- SAFETY RULES
- TUNE-UP PROCEDURES
- REPAIR PARTS

SEARS, ROEBUCK AND CO. U.S.A.
CHICAGO, ILLINOIS 60684

TABLE OF CONTENTS

Title	Page
RULES FOR SAFE AUTOMOTIVE TESTING	3
WARRANTY	3
CHAPTER 1. INTRODUCTION	
1-1. Introduction	4
1-2. Vehicle Manual	4
1-3. Safety Information	4
CHAPTER 2. DIAGNOSTIC ANALYZER CONTROLS, CONNECTIONS, AND ACCESSORIES	
2-1. Description	5
2-2. Leads Storage	9
2-3. Battery Replacement	9
2-4. Accessories	9
CHAPTER 3. TROUBLESHOOTING	
3-1. Introduction	10
3-2. Troubleshooting Chart	10
CHAPTER 4. DISABLING PROCEDURES	
4-1. Introduction	11
4-2. Breaker Points Ignition Systems or Electronic Systems with Separate Coil — AMC/FORD/CHRYSLER	11
4-3. E Core Coil—GM HEI External Coil and Ford TFI	11
4-4. GM HEI Integral Coil	12
4-5. GM Diagnostic Connector	12
4-6. Imported Vehicles	12
A. Toyota	12
B. Nissan—Datsun Vehicles with NAPS-Z Engine	13
C. Nissan—Datsun Vehicles without NAPS-Z Engines—HITACHI Electronic Ignition	13
D. Mazda Vehicles with Rotary Engines	13
CHAPTER 5. ELECTRICAL SYSTEM—PRELIMINARY CHECKS	
5-1. Introduction	14
5-2. Vehicle Checks	14
CHAPTER 6. CRANKING SYSTEM TESTS	
6-1. Description	15
6-2. Cranking Voltage, Starter Current Draw and Battery Condition	15
6-3. Cranking Circuit Voltage Loss Test	16
CHAPTER 7. CHARGING SYSTEM TESTS	
7-1. Description	18
7-2. Charging System Voltage and Battery Charging Current Test	18
7-3. Alternator Condition Test	21
7-4. Alternator Output Test	23
CHAPTER 8. IGNITION SYSTEM TESTS	
8-1. Description	30
Section 1. Primary Circuit	
8-2. Primary Coil Voltage with Ballast Resistor	30
8-3. Primary Coil Voltage without Ballast Resistor	32
8-4. Breaker Point Resistance Test	33
8-5. Dwell Test and Adjustment	35
8-6. Dwell Variation	38
Section 2. Secondary Circuit	
8-7. Cranking Coil Output Test	39
8-8. Spark Plug Firing Voltage Test	41
8-9. Spark Plugs Under Load Test	43
8-10. Coil Reserve Voltage Test	43
8-11. Secondary Insulation Test	45

	Page
CHAPTER 9. FUEL SYSTEM TESTS AND ADJUSTMENTS	
9-1. Description	48
Section 1. Mechanically Controlled Carburetors	
9-2. Mixture Adjustment: Pre-1980 1/2	48
9-3. Idle Speed and Throttle Kicking Solenoid Adjustments	49
Section 2. Electronically Controlled Carburetors — 1980 to 1984	
9-4. Description	53
9-5. General Motors C-3 System Performance Check — Computer Command Control	53
9-6. Chrysler EFCS — Electronic Fuel Control System Performance Check, 1981-1984	56
9-7. Ford Motor Company Electronic Engine Control Systems — Performance Checks — 1981-1984	58
9-8. Electronically Controlled Fuel Systems — IMPORTS	58
Section 3. Fuel Injection	
9-9. Description	59
CHAPTER 10. OHMMETER TESTING	
10-1. Description	61
10-2. Directions for Use	61
10-3. Spark Plug Wires	61
10-4. Alternator Testing	63
10-5. Rectifier Diode Tests	64
10-6. Rotor Tests (Alternator Field Coil)	65
10-7. Stator Tests	66
10-8. Ignition Coil Testing	67
10-9. Magnetic Pickup Coil Test	69
10-10. Testing Solenoids	72
10-11. Ballast Resistor Testing	72
APPENDIX A. Engine Timing	74
APPENDIX B. Replacement Parts Diagram and Ordering Instructions	75

RULES FOR SAFE AUTOMOTIVE TESTING

WARNING — READ CAREFULLY

Read this Operation Instruction Manual and these Rules for Safe Automotive Testing carefully. Failure to follow instructions and safety rules could result in serious bodily injury and/or damage to the instrument.

1. Before starting the engine, set the parking brake and place the gear selector in NEUTRAL on standard transmissions and PARK on automatic transmissions.
2. The carbon monoxide in exhaust gas is highly toxic. To avoid asphyxiation, always operate vehicle in a well-ventilated area. If vehicle is in an enclosed area, exhaust should be routed directly to the outside via leak-proof exhaust hose.
3. To avoid explosion due to spark when operating any test instrument from an auxiliary battery, connect a jumper wire between the negative terminal of the auxiliary battery and chassis ground on the vehicle under test for negative ground systems. For positive ground systems, connect the jumper wire to the positive terminal of the auxiliary battery and chassis ground on the vehicle. When working in a garage or other enclosed area, auxiliary battery should be located at least 18 inches above the floor to minimize the possibility of sparks igniting gasoline vapors and causing an explosion.
4. An automobile battery is capable of producing very high currents. Therefore, exercise reasonable care when working near the battery to avoid electrical connections through tools, wrist-watch, etc.
5. Avoid contact with battery electrolyte. Electrolyte can burn holes in clothing, burn skin and cause permanent damage to eyes. Always wear splash-proof safety goggles when working around the battery. If battery electrolyte is splashed in the eyes or on skin, immediately flush the affected area for 15 minutes with large quantities of clean water; in case of eye contact, seek medical aid immediately.
6. The gases generated by a charging battery are highly explosive. Do not smoke or permit flame or spark to occur near a battery at any time, particularly when it is charging. Any room or compartment containing charging batteries should be well ventilated to prevent accumulation of explosive gases. To avoid sparks, do not disturb the battery charger connections while battery is charging, and always turn charger off before disconnecting the battery clips. When removing or reconnecting battery cables, make sure ignition switch and all accessories are turned off. A technique used by many mechanics is to carefully blow across the top of the battery to remove any hydrogen gas accumulation before connecting or disconnecting battery clips.
7. Never add acid to a battery once the battery has been placed in service; doing so may result in dangerous spattering of electrolyte.
8. Keep hands, hair, necktie, loose clothing and test leads well away from fan blades, fan belt, power steering belt, air conditioner belt and other moving engine parts as serious injury could result from entanglement.
9. Do not touch hot exhaust manifold, radiator or high-voltage spark plug and coil terminals. Spark voltages are not normally lethal, but an involuntary jerk of the hands or arms caused by electrical shock may result in injury.
10. Never look directly into carburetor throat while engine is cranking or running. A sudden backfire can cause serious burns.
11. To avoid the possibility of a flash fire, do not smoke or permit flame or spark to occur near carburetor, fuel line, fuel filter, fuel pump or other potential sources of spilled gasoline or gasoline vapors.
12. Never remove radiator cap while the engine is hot. Hot coolant escaping under pressure can cause serious burns.
13. The jack supplied with the vehicle should be used only for changing wheels. Never crawl under car or run engine while vehicle is on jack.
14. When making electrical test connections to the vehicle, do not use the carburetor or other fuel system components as a ground connection, as a spark could ignite the gasoline vapors and cause a fire or an explosion.
15. Do not let test cables rest or fall on or near hot or moving engine parts.
16. Use caution when disconnecting ignition cables. Pull cables carefully at the boot with the proper tool.
17. Always turn the Diagnostic Analyzer OFF before disconnecting it from battery.

FULL ONE-YEAR WARRANTY

If, within 1 year from the date of purchase, this automotive test instrument fails due to a defect in material or workmanship, RETURN IT TO NEAREST SEARS STORE IN THE UNITED STATES, and Sears will repair or replace it, free of charge.

This warranty gives you specific legal rights, and you may also have other rights which vary from state to state.

SEARS, ROEBUCK AND CO. • DEPARTMENT 698/731A
SEARS TOWER • CHICAGO, IL 60684

CHAPTER 1. INTRODUCTION

1-1. INTRODUCTION This owner's manual describes the Sears' Craftsman Model 161.21045 Diagnostic Analyzer and the tests that it can do. Prior to performing any analyzer test, however, it is important that the technician understands how to use this manual and how to apply the tests described for the specific vehicle being serviced.

IMPORTANT

CONSULT THE VEHICLE SERVICE MANUAL FOR SPECIFIC TUNE-UP INFORMATION AND TEST PROCEDURES. ALWAYS FOLLOW THE MANUFACTURER'S SPECIFICATIONS AND TEST PROCEDURES FOR ADJUSTING DWELL ANGLE, IDLE SPEED, AND CHARGING SYSTEM OUTPUT, ESPECIALLY VEHICLES WITH MODERN ELECTRONIC IGNITION AND EMISSION CONTROLS. DO NOT ATTEMPT TO SERVICE A VEHICLE WITHOUT THE MANUFACTURER'S INSTRUCTIONS AND SPECIFICATIONS.

1-2. VEHICLE MANUAL. SOURCES FOR SERVICE INFORMATION. The following is a list of publishers who have service manuals for your specific vehicle at nominal cost. Write to them for availability and prices, specifying the make, style, and model year of your vehicle.

American Motors Corporation
Myriad
8835 General Drive
Plymouth Township,
Michigan 48170

Chrysler Corporation
Dymont Distribution Service
Service Publication
20026 Progress Drive
Strongsville, Ohio 44136

Ford Publication Department
Helm Incorporated
Post Office Box 07150
Detroit, Michigan 48207

Buick
Tuar Company
Post Office Box 354
Flint, Michigan 48501

Oldsmobile
Lansing Lithographers
Post Office Box 23188
Lansing, Michigan 48909

Cadillac, Chevrolet, Pontiac
Helm Incorporated
Post Office Box 07130
Detroit, Michigan 48207

OTHER SOURCES NONFACTORY

Domestic and Import Cars

Chilton Book Company
Chilton Way
Radnor, PA 19089

Cordura Publications
Mitchell Manuals, Inc.
Post Office Box 26260
San Diego, CA 92126

Motor's Auto Repair Manual
Hearst Company
250 W. 55th Street
New York, N.Y. 10019

1-3. SAFETY INFORMATION. Throughout this manual, information which is especially critical to personnel or equipment safety is presented as notes which interrupt the text. The terms "WARNING," "CAUTION," and "NOTE" have the following meanings:

WARNING

Warning notices are used to emphasize conditions in the operation of the equipment that could cause injury to personnel.

CAUTION

Caution notices are used to emphasize conditions in the operation of the equipment that could cause damage to equipment.

NOTE

Notes call attention to information that is especially significant in understanding or operating this equipment.

CHAPTER 2. DIAGNOSTIC ANALYZER CONTROLS, CONNECTIONS, AND ACCESSORIES

2-1. DESCRIPTION. The Model 161.21045 Diagnostic Analyzer has clearly labeled controls and meters as shown in Figure 2-1. It is actually two separate instruments in one case. The digital portion on the right side of the front panel is powered by an internal 9 volt battery which makes it a portable instrument for digital measurements. The left side is an analog meter, and the instrument must be connected to the vehicle under test in order to make these measurements. Follow the connection procedures discussed below and in each section of this manual where a test is explained.

The digital display on the right side of the panel (6) provides a sharp, clear display of the Voltage, Dwell, and Ohmmeter readings as selected by the Digital Function Selector Switch (7). The left side of the panel contains a precision Analog Meter (1) which accurately displays functions that are best shown by a moving pointer. Small changes in RPM, AMPS, KV, and GM C-3 dwell are easily followed and can aid in troubleshooting problems in the various electrical systems of the vehicle. These analog measurements are selected by the Analog Function Selector Switch (4).

WARNING

THIS INSTRUMENT IS NOT DESIGNED TO MEASURE AC (ALTERNATING CURRENT) VOLTAGES. IF AN ATTEMPT IS MADE TO USE IT IN SERVICING HOUSEHOLD APPLIANCES OR EQUIPMENT WHICH OPERATES FROM THE 110 VOLT AC POWER SOURCE, PERMANENT DAMAGE CAN RESULT TO THE INSTRUMENT AND CREATE A SAFETY HAZARD TO OPERATING PERSONNEL. CAREFULLY FOLLOW ALL CONNECTION INSTRUCTIONS IN THIS MANUAL AND BECOME FAMILIAR WITH THE SAFETY RULES ON PAGE 3.

CAUTION

The Sears 21045 Analyzer uses the battery of the vehicle under test as its power source for all functions except the digital OHMS, DWELL, and VOLTS. The digital section uses an internal 9 volt battery which allows OHMS and VOLTS tests to be performed on or off the vehicle. The Analyzer is capable of working on both 12 and 24 volt Negative (-) ground electrical systems. Before starting to troubleshoot, check the vehicle's battery voltage. If it is under 9.5 volts, use an auxiliary 12 volt battery.

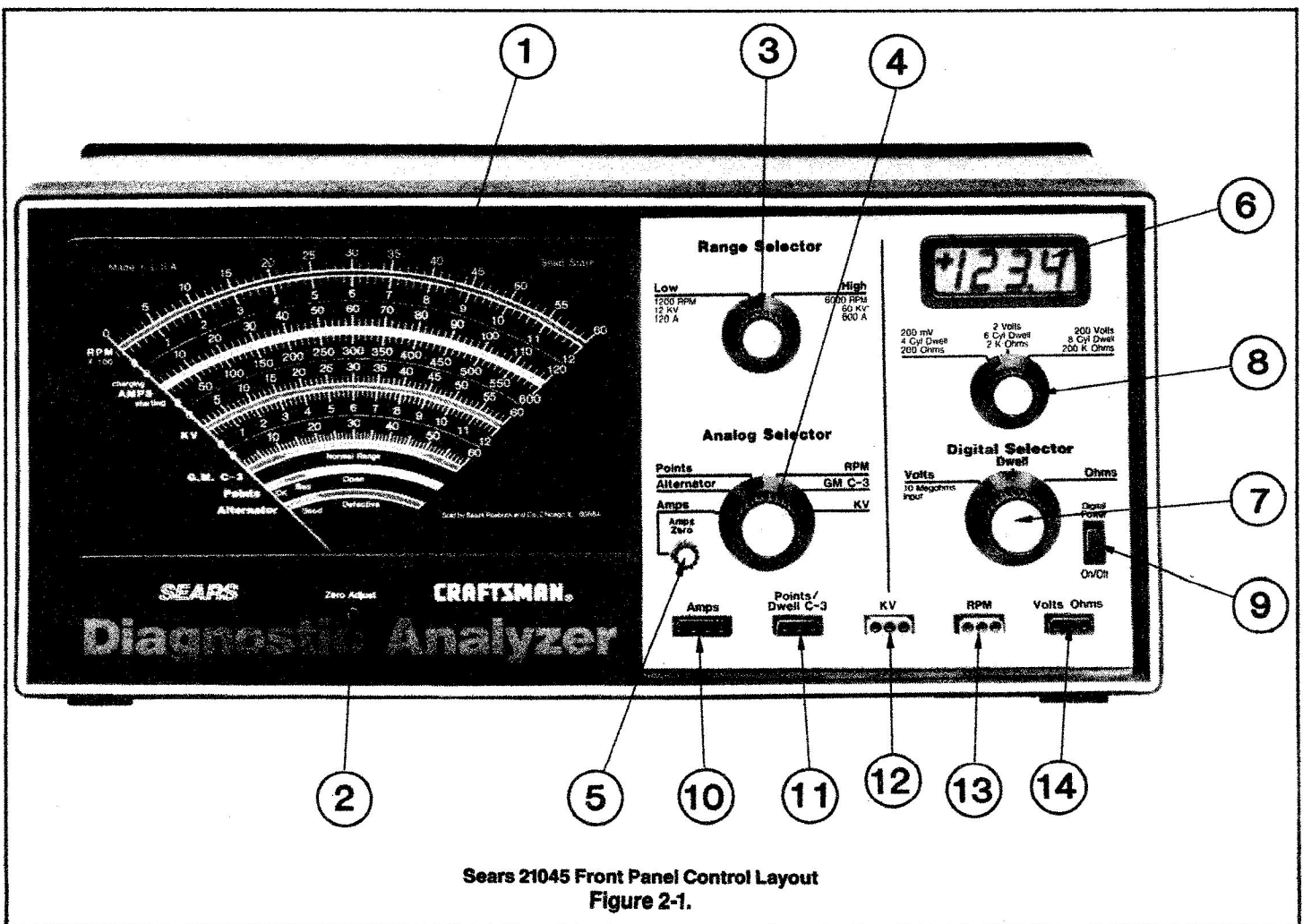

Sears 21045 Front Panel Control Layout
Figure 2-1.

TABLE 2-1 PANEL CONTROLS, CONNECTIONS, ACCESSORIES, and FUNCTIONS

Panel Controls and Functions (See Figure 2-1.)

1. ANALOG METER

This 8 inch easy-to-read meter displays a total of nine scales:

- RPM
 - a. 0 to 1200 Low Range
 - b. 0 to 6000 High Range
- Amperes
 - a. 0 to 120 Low Range
 - b. 0 to 600 High Range
- KV (Ignition Kilovolts)
 - a. 0 to 60 High Range
 - b. 0 to 12 Low Range
- GM C-3 System Dwell (General Motors Computer Command Control)
 - a. 0 to 60 Range
 - b. 10 to 50 Normal Range for Varying Dwell Operation
- Points
 - a. OK
 - b. Bad
 - c. Open
- Alternator — Good/Defective Band

2. ANALOG METER ZERO ADJUSTER

Before any connections are made, if necessary, rotate the adjuster slowly with a screwdriver until the pointer is on zero.

3. ANALOG RANGE SELECTOR

The ANALOG RANGE SELECTOR sets the High or Low range for RPM, KV, and AMPS tests. The ANALOG RANGE SELECTOR affects the ANALOG METER readings only.

4. ANALOG FUNCTION SELECTOR

This selector sets the Amps, Alternator, Points, RPM, GM C-3, and KV functions for the Analyzer. Results of these functions are read on the ANALOG METER. This selector affects only the ANALOG METER.

CAUTION

The Points function cannot be performed while the engine is running; the ANALOG METER will indicate erroneous readings if attempted.

5. AMPS ZERO

The AMPS ZERO adjuster sets the ANALOG METER to zero after the Alt/Amps lead is in its socket and the ANALOG FUNCTION SELECTOR switch is in the Amps position. This zero adjustment must be made before making Amps and Alternator tests. See Alternator tests and Amps tests, Chapters 6 and 7, of this manual for complete instructions on use.

NOTE

The pointer of the ANALOG METER will read to the left of zero if the Analyzer is operated without the Amps pickup connected AND the ANALOG FUNCTION SELECTOR is placed in the Amps position. This is normal for the Analyzer: the Amps pickup lead must be connected for the Amps Zero adjuster to return the pointer to zero.

6. DIGITAL DISPLAY

The DIGITAL DISPLAY records the results of Volts, Dwell, and Ohms tests in contrasting, easy-to-read black-on-silver digits. The display indicates Negative (-) polarity on the voltage scale when the test leads are reversed from the normal position.

The Dwell and Voltmeter values are read directly on the Digital Display with the decimal point properly located. The Ohmmeter function, however, requires the value displayed on the 2 K-Ohms and 200 K-Ohms ranges be multiplied by 1000 to obtain the proper reading in ohms. See Table 2-2, Ohmmeter Readings and Multiplier Values for a description of how to adjust the decimal point for the thousand-ohm ranges.

NOTE

A common symbol used to denote ohms is the Greek OMEGA sign: Ω . Likewise, the letter K is a shorthand abbreviation used to represent 1000, in order to keep larger numbers of ohms more manageable. Example: 1000 ohms = 1 K Ω

NOTE

AUTO-POLARITY — DIGITAL VOLTMETER

This analyzer is equipped with an automatic voltage polarity indicating circuit. If you connect the negative (BLACK) Digital Voltmeter lead to the positive terminal of a battery (or other voltage source) and the positive (RED) Digital Voltmeter lead to the negative terminal, a negative (-) sign will appear in the digital display. Reversing the leads will cause the negative sign to disappear. The voltage value will be the same in either case and should cause no concern.

7. DIGITAL FUNCTION SELECTOR

The DIGITAL FUNCTION SELECTOR switch selects Volts, Dwell or Ohms. Results of these functions are read on the DIGITAL DISPLAY.

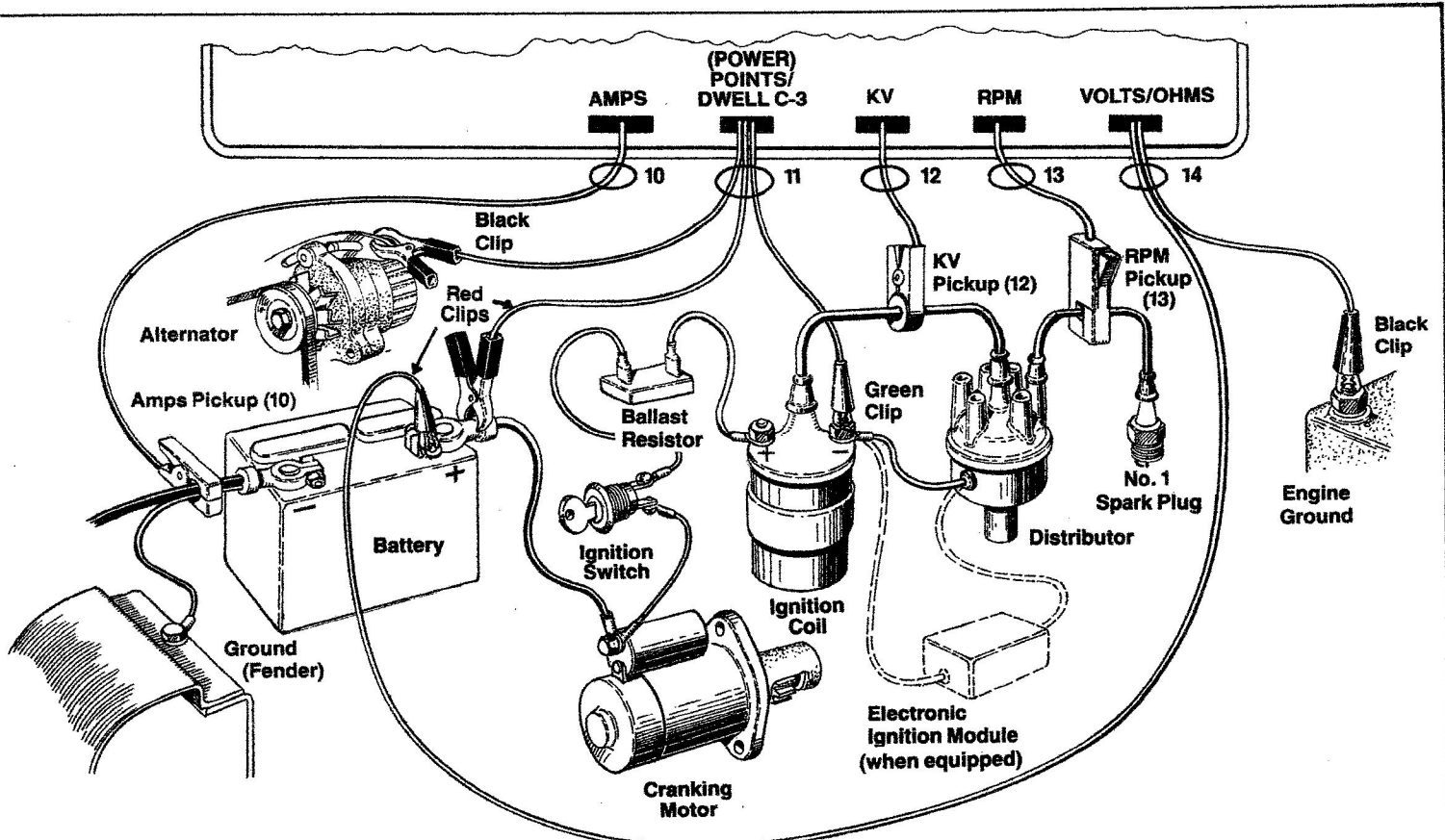

Sears 21045 Master Hookup Diagram
Figure 2-2A

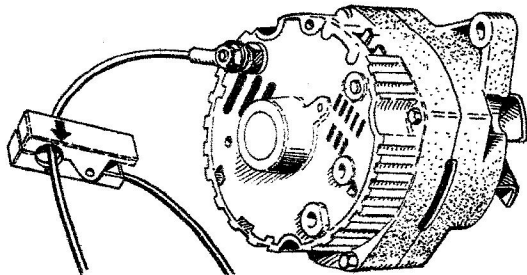

Ams Pickup — Alternator Output
Figure 2-2B

Connection Variations and Alternate Locations (Typical)

Dwell Connector (Green)

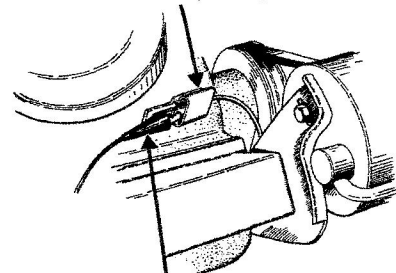

Green clip or Ground Jumper
See text.

GM C-3 (Computer Command Control) Performance Check
Figure 2-2C

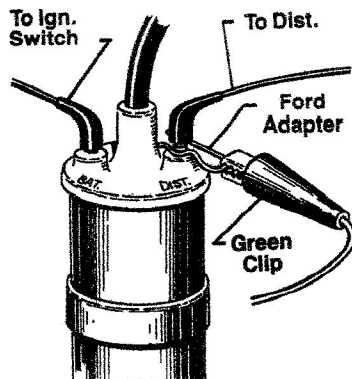

Primary Coil Adapter Included

FORD BREAKER POINT IGNITION SYSTEMS
Figure 2-2D

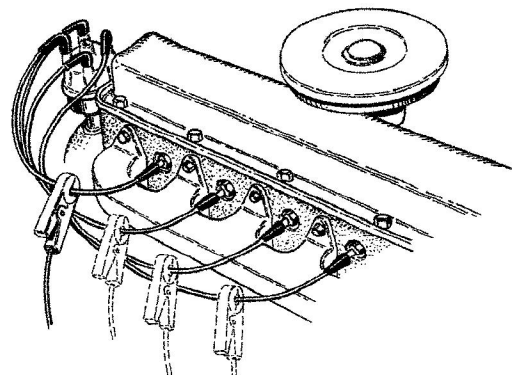

KV Pickup (12) Wire to Wire Installation (As Required)
Figure 2-2E

TABLE 2-2 OHMMETER READINGS AND MULTIPLIER VALUES			
SELECTOR	RANGE	MULTIPLIER	SMALLEST NUMBER READABLE
200 Ohms	.1Ω to 199.9Ω	1	.1Ω
A. EXAMPLES:			
	3.3 ohm resistor =	03.3 x 1	= 3.3Ω
	25 ohm resistor =	25.0 x 1	= 25Ω
	160 ohm resistor =	160.0 x 1	= 160Ω
2 K-Ohms	1Ω to 1.999 KΩ	1000	1Ω
B. EXAMPLES:			
	1800 ohm resistor =	1.800 x 1000	= 1800Ω
or	1800 ohm resistor =	1.800 x 1K	= 1.8KΩ
	330 ohm resistor =	.330 x 1000	= 330Ω
200 K-Ohms	100Ω to 199.9 KΩ	1000	100Ω
C. EXAMPLES:			
	20,000 ohm resistor =	20.0 x 1000	= 20,000Ω
or	20,000 ohm resistor =	20.0 x 1KΩ	= 20 KΩ
	150,000 ohm resistor =	150.0 x 1000	= 150,000Ω
or	150,000 ohm resistor =	150.0 x 1KΩ	= 150 KΩ

CAUTION

The ANALOG FUNCTION SELECTOR should not be in the Points position when the engine is running or when the DIGITAL FUNCTION SELECTOR is in the Dwell position; the ANALOG METER will indicate erroneous readings if attempted.

8. DIGITAL RANGE SELECTOR

The DIGITAL RANGE SELECTOR switch selects three ranges for Volts and Ohms, and selects 4, 6, or 8 cylinder positions for Dwell tests.

9. DIGITAL POWER ON/OFF Push Button

The DIGITAL POWER ON/OFF Push Button switch powers the Volts, Dwell, and Ohms functions of the Analyzer. When the button is pushed in (ON), the DIGITAL DISPLAY lights up. When the button is released (OFF), the DIGITAL DISPLAY goes blank.

SOCKETS AND LEADS CONNECTIONS

All plugs and sockets are color-coded and keyed to ensure correct connection. To check the color of any lead plug, look directly at the pin area of the plug. The top panel of Figure 2-2, Sears 21045 Master Hookup Diagram, illustrates the most common connection for each lead. These leads may be connected once at the beginning of any testing and left connected unless Hookup Procedures state otherwise. All leads are not required for all tests as indicated in the Hookup Procedure for each test. Leads which have multiple functions because of test or engine variations are listed on the bottom panel of Figure 2-2.

10. ALT/AMPS Socket

Insert the 4 pin BLACK ALTERNATOR/AMPS pickup lead into the 4 pin BLACK socket. Do not drop this pickup assembly or damage to the clamp can result. To maintain proper operation and accuracy, clean and dry the inside mating surfaces of this clamp with a soft cloth as shown in Figure 2-3.

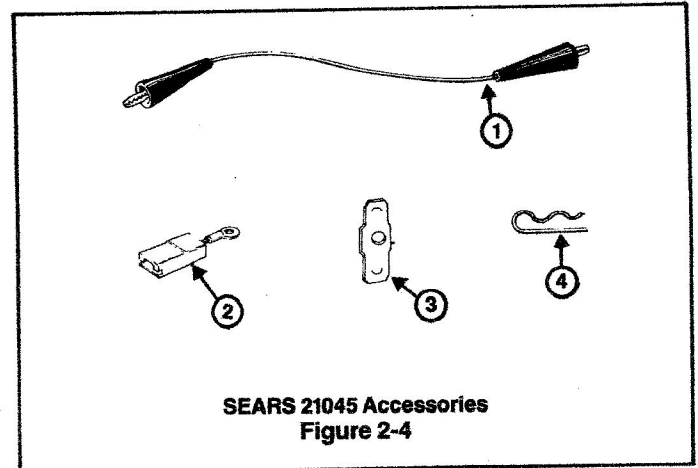
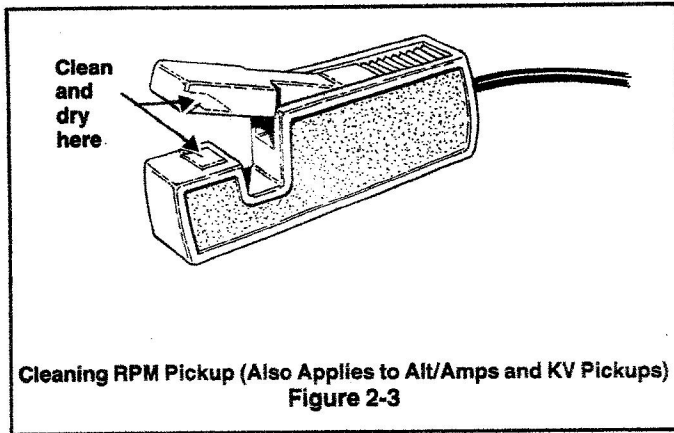

11. **POWER/POINTS/DWELL/C-3 Socket**
Insert the 3 pin BLACK POWER/POINTS/DWELL/C-3 lead into the 3 pin BLACK socket.
12. **KV (IGNITION KILOVOLTS) Socket**
Insert the 3 pin YELLOW KV pickup (capacitive pickup) lead in the YELLOW KV socket.
13. **RPM Socket**
Insert the BLUE RPM inductive pickup lead into the BLUE socket for RPM tests. Do not drop this pickup assembly or damage to the clamp can result. To maintain proper operation and accuracy, clean and dry the inside mating surfaces of this clamp with a soft cloth as shown in Figure 2-3.
14. **VOLTS/OHMS Socket**
Insert the WHITE VOLTS/OHMS lead into the WHITE VOLTS/OHMS socket.

NOTE: 10 MEG OHM INPUT IMPEDANCE

Beginning in 1978, many vehicles were built with on-board computers. These vehicles' engines require test equipment with a 10 Meg Ohm input impedance rating. Your Sears 21045 Analyzer meets this requirement and is totally compatible with these systems.

2-2. LEADS STORAGE. The Sears 21045 Analyzer provides an in-case storage compartment for leads and accessories at the rear of the instrument.

2-3. BATTERY REPLACEMENT. The DIGITAL DISPLAY (6) will read "LO BAT" when it is time to replace the 9 volt transistor battery. Replace the battery immediately. The 9 V battery is located in the upper left hand corner of the rear storage compartment for leads and accessories. Be sure to observe correct polarity when installing a new battery.

NOTE

The nine (9) volt battery which powers the digital portion of this analyzer is not supplied. Install a Sears #6417 battery or equivalent.

2-4. ACCESSORIES. See Figure 2-4.

1. JUMPER LEAD

The JUMPER LEAD is used for miscellaneous electrical system tests as described in the applicable section of this manual.

2. ALTERNATOR FIELD PLUG CONNECTOR

The ALTERNATOR FIELD PLUG CONNECTOR is used for Alternator Output Tests. See Figure 7-15 for installation and the description for use in Chapter 7, Alternator Output Tests.

3. GM DIAGNOSTIC ADAPTER

The GM DIAGNOSTIC ADAPTER is used with cars equipped with the GM (General Motors) diagnostic connector. See Figure 4-5 for installation and the description for use in Chapter 4, "Disabling Procedures."

4. PRIMARY COIL ADAPTER

The PRIMARY COIL ADAPTER is used for cars that have ignition systems with insulated coil primary connections. See Figure 2-2.

CHAPTER 4. DISABLING PROCEDURES

CAUTION

This manual highlights the most obvious Cautions, Notes, and Warnings. The technician should always check his vehicle service manual for any other engine-specific notices that affect the safety of a particular test for the technician and his vehicle.

4-1. Introduction. The technician must disable the ignition system to prevent the engine from starting during some electrical system tests. The following procedures describe various engine system types. Consult your vehicle service manual for proper procedures for ignition systems not presented.

CAUTION

Do not connect the tachometer terminal (Negative ignition coil terminal) to ground on any ignition system unless specifically directed by the vehicle's service manual. Damage to ignition system components may result.

4-2. BREAKER POINTS IGNITION SYSTEMS (ALL) OR ELECTRONIC SYSTEMS WITH SEPARATE COIL (AMC/FORD/CHRYSLER). To prevent the engine from starting while cranking, remove the high tension lead from the center of the distributor cap; ground the lead by connecting the loose end to the engine or frame, as shown in Figure 4-1. Be sure the clipped connections are secure.

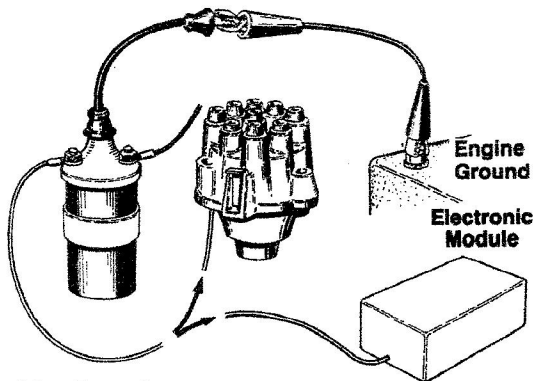

Disabling Procedure,
Breaker Point Ignition System or Electronic
System with Separate Coil (AMC/FORD/CHRYSLER)
FIGURE 4-1

4-3. E-Core Coil (GM HEI External Coil and Ford TFI). To prevent the engine from starting while cranking, remove the connector from the ignition coil as illustrated in Figures 4-2 and 4-3.

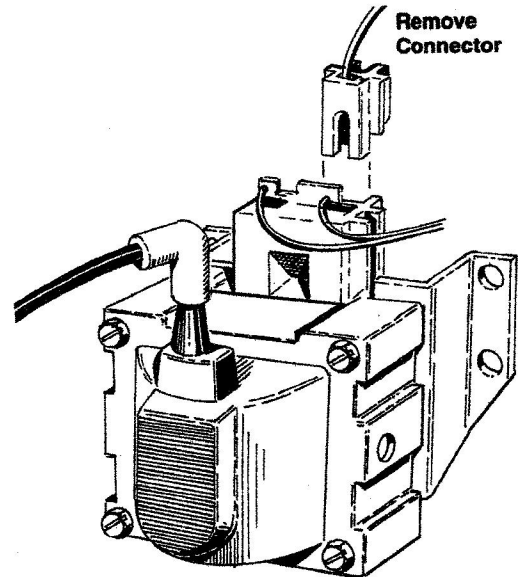

Disabling Procedure GM HEI (High Energy Ignition)
with External Coil

Figure 4-2

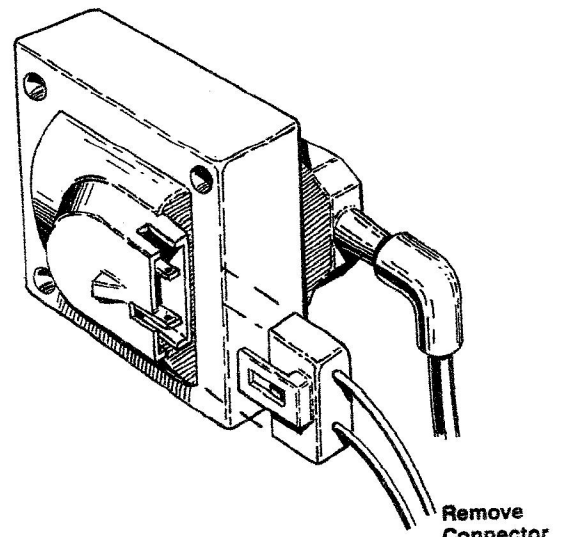

Disabling Procedure Ford TFI (Thick Film Ignition)
Figure 4-3

4-4. GM HEI Integral Coil. For systems with an integral coil as shown in Figure 4-4, disconnect the primary wire from the "BAT" terminal on the distributor cap. See Figure 4-4.

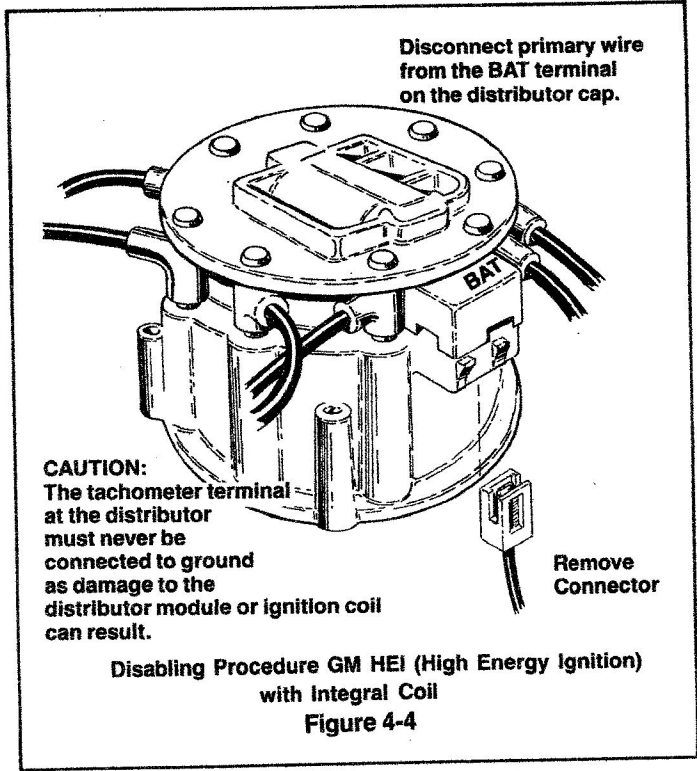

4-5. GM Diagnostic Connector. For systems with an electrical diagnostic connector as shown in Figure 4-5, insert the GM diagnostic spade adapter in terminal No. 6. Connect a jumper wire between this terminal and a secure ground on the engine or frame. Do not confuse this diagnostic connector with the A/C Heater diagnostic connector found on the passenger side of some vehicles. See Figure 4-5.

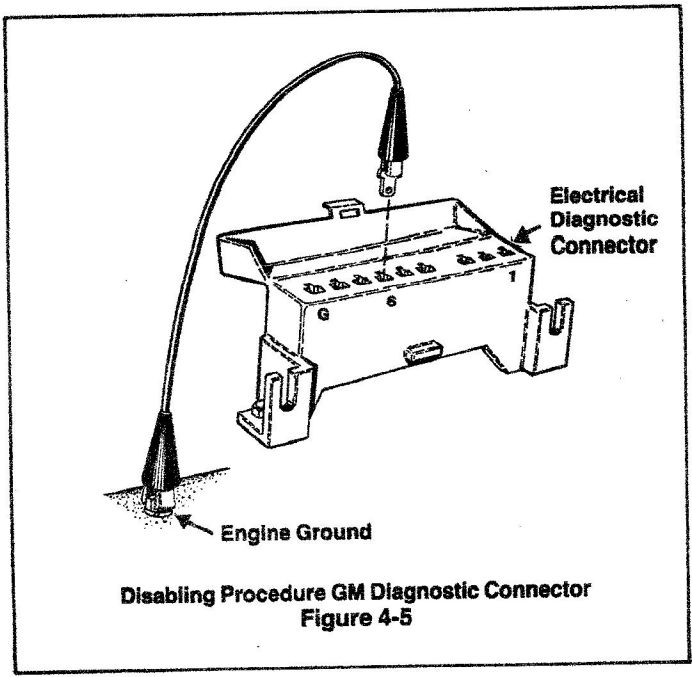

4-6. Imported Vehicles. The majority of imported vehicles can be easily disabled by removing the coil tower wire from the center of the distributor cap and securely grounding the tower wire with the jumper wire supplied with the Sears 21045 Analyzer. See Figure 4-6.

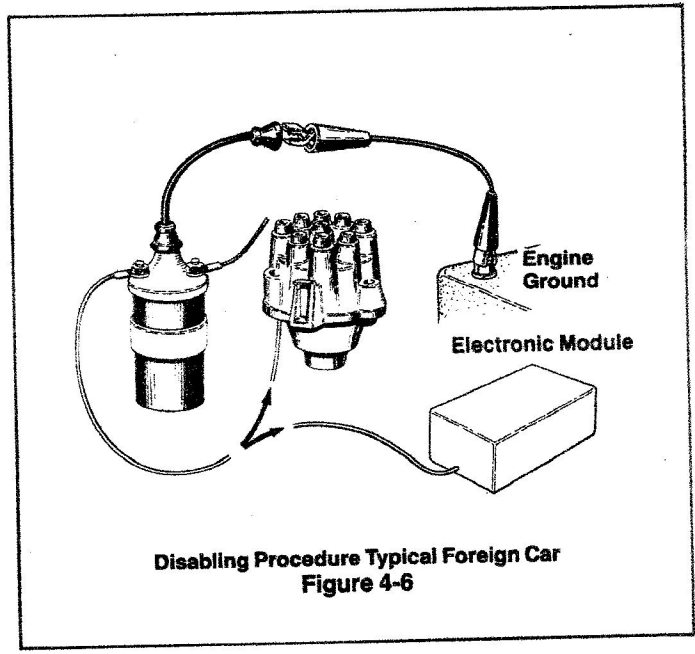

The following systems do not conform to the general rule above and must be disabled as described below:

A. TOYOTA.

Some late model Toyota engines use an IIA (Integrated Ignition Assembly). Do not confuse this system with the GM HEI. Disable the Toyota system by disconnecting the distributor connector as shown in Figure 4-7.

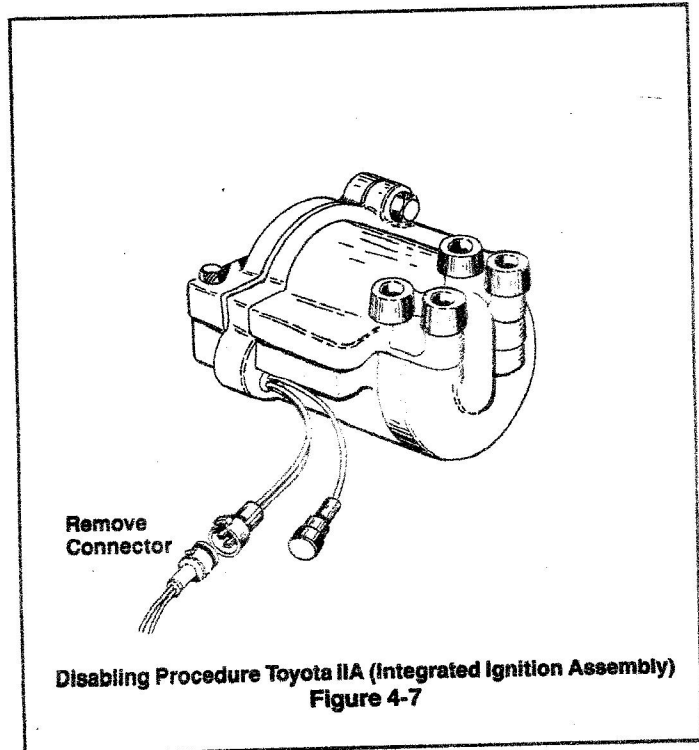

B. NISSAN-DATSUN Vehicles with NAPS-Z Engine.

Beginning in 1980 the Nissan NAPS-Z engine (4 cylinder) uses two spark plugs per cylinder, one on the intake side and one on the exhaust side of the cylinder. This engine may be disabled as indicated above, but BOTH coil tower wires must be removed and securely grounded to prevent the engine from starting. Mark each coil wire before removal so correct reconnection can be made. See Figure 4-8.

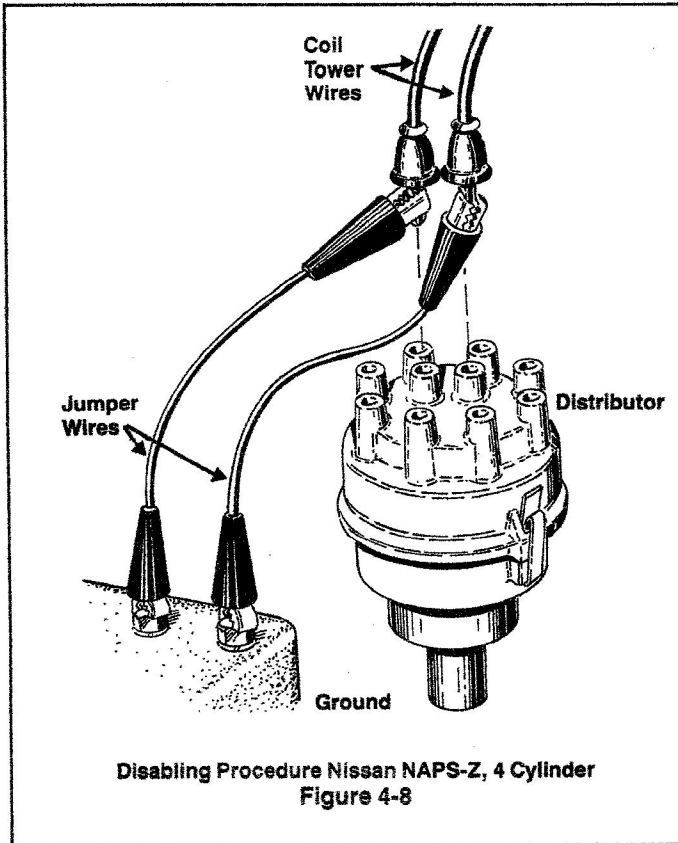

C. NISSAN-DATSUN Vehicles without the NAPS-Z Engines and using the HITACHI Electronic Ignition.

Remove the coil tower wire from the center of the distributor cap. Securely ground the tower wire with the jumper wire supplied with the Sears Analyzer. If it is more convenient, remove the two-pin connector on the IC ignition unit mounted on the distributor. See Figure 4-9.

D. MAZDA Vehicles with Rotary Engines

Mazda Rotary Engines use a "leading" and a "trailing" ignition system. Both systems must be disabled in the same way. Remove the coil tower wires from the distributor cap. Mark each coil tower wire so that they can be easily reconnected correctly later. Securely ground the tower wires with jumper wires. See Figure 4-10.

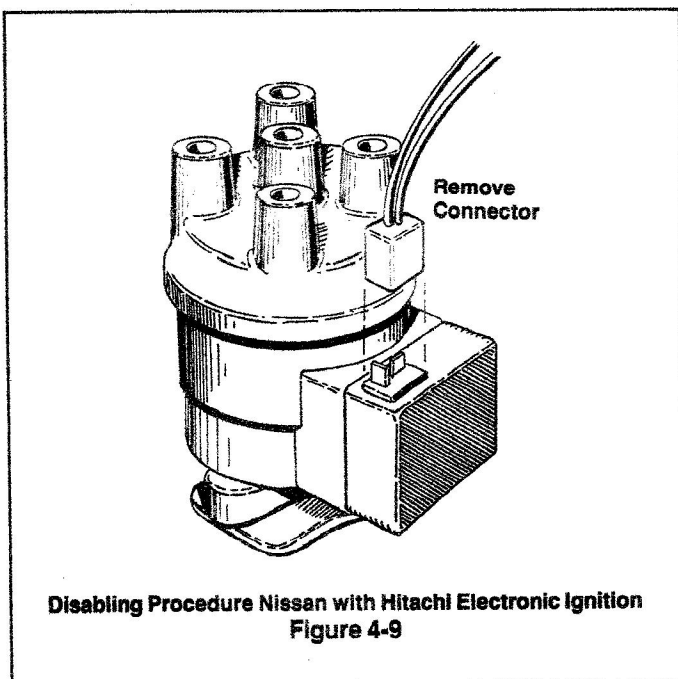
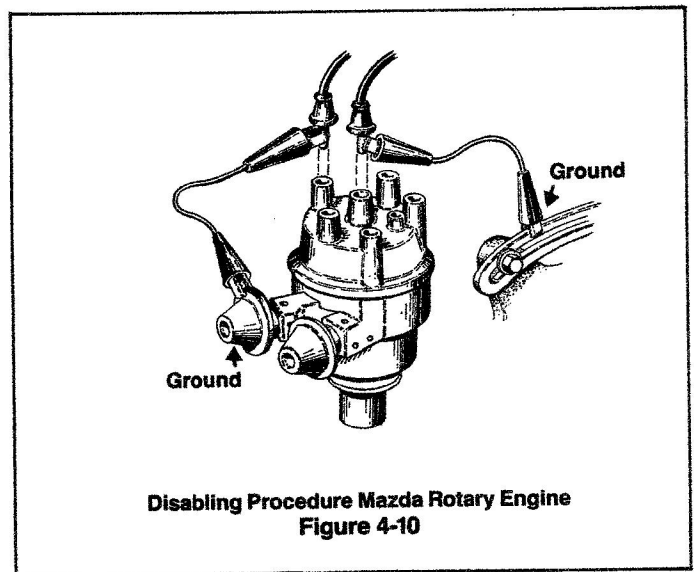

Chapter 5. ELECTRICAL SYSTEM — PRELIMINARY CHECKS

5-1. INTRODUCTION. Before performing any electrical system tests, carefully read the following information. These checks will help you to identify the more common electrical system problems and will serve as a general guide for making electrical system tests.

5-2. VEHICLE CHECKS.

A. CONSULT THE VEHICLE SERVICE MANUAL OF THE VEHICLE BEING TESTED FOR SPECIFIC VOLTAGE AND CURRENT SPECIFICATIONS AND TEST PROCEDURES.

B. Check the fan belt; tension it according to the manufacturer's specifications.

C. Check the generator or alternator pulley and mounting bolts. They should be tight. Make sure that the charging and cranking system wiring and the battery cables are in good condition and that connections are clean and tight. Make sure that the battery is clean and that the liquid level in each cell is above the plates on vent-cap style batteries or that the green "eye" is visible on maintenance-free batteries.

D. Check the "CCA" (Cold Cranking Amps) rating of the vehicle battery, often listed on the battery. This number should equal or exceed the specification given by the manufacturer for the vehicle's engine. If the battery capacity is too small, a cold engine may crank slowly or not at all on very cold days. If specifications are not available, the following method may be used to determine the recommended battery capacity.

1. 8 CYLINDER ENGINES. The cubic inch displacement, (CID — not liters) equals the Cold Cranking Amp requirement. For example, a 350 cubic inch displacement engine equals a 350 CCA minimum. For cold climates, add 20 % of the cubic inch displacement to the CCA. Therefore, $350 \times .2 (20\%) = 70$. $350 + 70 = 420$. A 420 CCA or greater rated battery should be used.

2. 6 CYLINDER ENGINES. Calculate the cubic inch displacement per cylinder and multiply by 8. For example, a 231 cubic inch displacement 6 cylinder engine = 38.5 cubic inch displacement per cylinder. Then, $38.5 \times 8 = 308$ CCA minimum. For cold climates, add 20 % of the adjusted cubic inch displacement to the CCA. Therefore, $308 \times .2 (20\%) = 62$. $308 + 62 = 370$. A 370 CCA battery or greater should be used.

3. 4 CYLINDER ENGINES. Multiply the cubic inch displacement of the engine by 2. For example, a 151 cubic inch displacement engine $\times 2 = 302$ CCA. For cold climates, add 20 % of the adjusted cubic inch displacement to the CCA. Therefore, $302 \times .2 (20\%) = 60$. $302 + 60 = 362$. A 362 CCA or greater rated battery should be used.

E. Check the alternator/generator output rating as listed on its color-coded tag or stamped on the alternator/generator frame. For example, 60A or 100A indicates a 60 Ampere or 100 Ampere alternator/generator. This rating should equal or exceed the manufacturer's specification for the vehicle as equipped. An alternator/generator which is electrically too small for the vehicle can excessively discharge a battery when the vehicle is run under heavy electrically loaded conditions (lights, HI fan, air conditioning etc.). The result could be a NO Crank/Start condition after prolonged operation under heavy electrical load conditions.

G. Electrical specifications are generally given for an engine which is at normal operating temperature. If the engine is cold and will start, operate the engine at idle speed for at least 10 minutes before making any tests or until it is fully warm (upper radiator hose is hot). If the engine will not start and the cranking system tests must be made on a cold engine, cranking voltage may be slightly lower and current draw slightly higher than specifications state.